

MOD. W1894 CARBINE



A. Uberti S.p.A.

Via Artigiani, 1 - Gardone V.T. (Brescia) - ITALY

Instruction Manual

BEFORE REMOVING THE FIREARM FROM THIS PACKAGE,
READ & UNDERSTAND THE PRECAUTIONS IN THE
INSTRUCTIONS MANUAL

MOD. W1894

SPECIAL SAFETY INSTRUCTIONS

- 1) Uberti lever action rifles should never be carried with a cartridge in the chamber.
- 2) Carrying this style of rifle with a cartridge in the chamber can result in an accidental discharge if the firearm is accidentally dropped or if the hammer is struck.
- 3) The lever locking mechanism is designed to prevent an accidental discharge. However, no mechanical device is foolproof and, accordingly, these procedures must be followed.
- 4) Due to the fact that in a tubular magazine rifle the cartridges are stacked one behind the other, only factory ammunition should be used.
- 5) We recommend against using old ammunition in these rifles as primers, powder and brass cartridge cases can deteriorate and cause damage to the rifle or injury to the shooter or others.
- 6) Uberti assumes no liability for incidents occurring through the use of reloaded ammunitions.
Use **ONLY COMMERCIALY** loaded cartridges that have been loaded in accordance with SAAMI-C.I.P. standards.

LOADING THE FIREARM

(1) Load the tubular magazine by pressing the cartridge into the ladle, which is located on the right side of the receiver. Push the cartridge forward and insert it into the tubular magazine (Fig. 1).



When loading cartridges through the ladle, leave the rim of each cartridge protruding sufficiently to hold the ladle open.

When loading the last cartridge, insert it fully into the magazine thereby allowing the ladle to close. Do not insist on forcing the spring. Overloading the magazine may result in improper feeding.

(2) When you are ready to actually fire the firearm, the lever is pushed forward as far as it will go and is then pulled straight back. Your finger should **NOT TOUCH THE TRIGGER** while manipulating the lever. (Fig. 2).

The rifle will now be fully cocked and will fire when the trigger is pulled.



These firearms have been equipped with an additional safety system (Fig. 3), which should prevent the firearm from firing until the lever is squeezed flush with the frame. This safety, however, is not designed to replace basic safe firearms handling. Accordingly, **NEVER** touch the trigger until you intend to fire.

After you have fired the first shot, the next cartridge is loaded by repeating step 2.

N.	Q.ty	Description	N.	Q.ty	Description
1	1	Frame	98	1	Firing Pin
2	1	Hammer	99	1	Trigger Pin
3	1	Barrel 20" Cal.30-30	101	1	Lever Screw
7	1	Carrier Block Cal.30-30	104	2	Firing Pin Extension Pin
15	1	Sight	107	1	Lever Pin
19	1	Trigger Spring	108	1	Extractor Pin
20	1	Mainspring	111	1	Safety Spring Pin
26	1	Triggerguard	112	1	Stirrup Pin
31	2	Triggerguard Screw	113	1	Magazine Follower Cal.45/Cal.44-40
36	1	Mainspring Screw	114	1	Magazine Tube Plug
53	1	Mainspring Adjust Screw	115	1	Hammer Stirrup
55	1	Rear Sight	118	1	Magazine Tube 20"
57	1	Rough Butt Stock	119	2	Locking Screw
57	1	Polished Butt Stock & Plate	121	1	Band Screw
58	1	Rough Butt Plate	122	1	Forend Screw
61	1	Rear Sight Ramp	124	1	Lever Spring Screw
62	2	Butt Plate Screw	127	1	Ladle
63	1	Tang Screw	128	1	Ladle Screw
67	1	Firing Pin Extension	132	1	Ejector
68	1	Rough Forend 20"	135	1	Ejector Spring
68	1	Polished Forend 20"	170	1	Locking Brace
78	1	Cartridge Stop	185	2	Inside Guide Plate Screw
79	1	Extractor Cal.30-30	240	1	Trigger Spring Screw
80	1	Front Band	247	1	Plug Screw
81	1	Forend Band	248	1	Right Breech Block Guide Plate
87	1	Plain Trigger	249	1	Left Breech Block Guide Plate
88	1	Plain Sear	309	1	Breech Block Pin Plug Screw
89	1	Lever	449	1	Lever Pin
91	1	Safety Bar	713	1	Cartridge Stop Pin
93	1	Carrier Block Spring	738	2	Plug Frame Screw
94	1	Safety Spring	774	1	Ejector Pin
95	1	Firing Pin Spring	816	1	Cartridge Stop Plug
96	1	Magazine Spring 20"	A1	1	Hammer Assembly
97	1	Breech Block Cal.30-30			

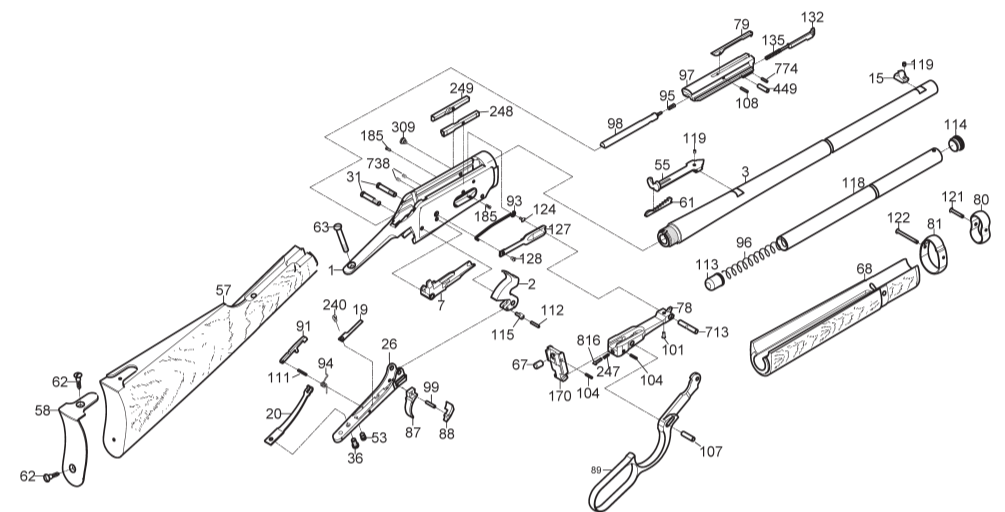

UNLOADING THE FIREARM

(1) To unload the firearm it is essential that the lever not be squeezed flush with the frame, as doing so would disengage the safety lock.

(2) With the firearm pointed in a safe direction, place your fingers through the rear portion of the loading lever. Be sure your first and second fingers are inside the lever loop. **DO NOT TOUCH THE TRIGGER.** Then push the lever straight forward and then pull it back. The cartridge that was in the chamber should be automatically ejected by the firearm and another cartridge from the magazine will be automatically loaded into the firearm. (Fig. 4).



(3) Repeat step 2 until all cartridges have been ejected from the firearm.

After all cartridges have been ejected, cycle the action four or five more times as described in step 2 as an added precaution to assure that all rounds were ejected.

(4) After step 3, move the lever to the forward position while visually inspecting **both the chamber and the carrier block**, to confirm that no cartridges are still in the firearm.

(5) Pull the lever to the rear, squeeze the loading lever flush with the frame and with your thumb on the hammer, pull the trigger and with your thumb slowly lower the hammer.

SAFETY MANUAL

This Manual Should Always Accompany this Firearm and Be Transferred With It Upon Change of Ownership

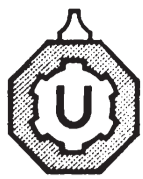

A. Uberti S.p.A.

SAFETY INSTRUCTIONS

Whether you are an experienced safe shooter and are familiar with these safety instruction procedures, or have some or no familiarity with handling a gun, it is imperative that you read carefully and thoroughly this entire instruction manual and follow the safety instructions to ensure you are familiar with the proper and safe use of this firearm to prevent personal injury, death, or property damage.

! WARNING:

• NEVER POINT A FIREARM AT SOMETHING THAT IS NOT SAFE TO SHOOT.

Never let the muzzle of a firearm point at any part of your body or at another person. This is especially important when loading or unloading the firearm. When you are shooting at a target, know what is behind it. Some bullets can travel over a mile. If you miss your target or if the bullet penetrates the target, it is your responsibility to ensure that the shot does not cause unintended injury or damage.

• ALWAYS TREAT A FIREARM AS IF IT WERE LOADED.

Never assume that a firearm is unloaded.

The only certain way to ensure that a firearm has the chamber empty is to open the chamber and visually examine the inside to see if a round is present. Removing the magazine will not guarantee that a firearm is unloaded or cannot fire. Shotguns and rifles can be checked by cycling or removing all rounds and by then opening and inspecting the chamber and the magazine tube for any remaining rounds.

• KNOW THE SAFETY FEATURES OF THE FIREARM YOU ARE USING, BUT REMEMBER: SAFETY DEVICES ARE NOT A SUBSTITUTE FOR SAFE HANDLING PROCEDURES.

Never rely solely on a safety device to prevent an accident. It is imperative that you know and use the safety features of the particular firearm you are handling, but accidents can best be prevented by following the safe handling procedures described in these safety rules and elsewhere in the product manual. To further familiarize yourself with the proper use of this or other firearms, take a Firearms Safety Course taught by an expert in firearms use and safety procedures.

• NEVER TRANSPORT A LOADED FIREARM.

Unload a firearm before putting it in a vehicle (chamber empty, magazine empty). Hunters and target shooters should load their firearm only at their destination. If you carry a firearm for self-protection, leaving the chamber unloaded can reduce the chance of accidental discharge.

• AVOID ALCOHOLIC BEVERAGES OR JUDGMENT/REFLEX IMPAIRING MEDICATION WHEN SHOOTING.

Do not drink and shoot. If you take medication that can impair motor reactions or judgment, do not handle a firearm while you are under the influence of the medication.



• ALWAYS WEAR PROTECTIVE GLASSES AND EARPLUGS WHEN SHOOTING.

The chance that gas, gunpowder or metal fragments will blow back and injure a shooter who is firing a gun is rare, but the injury that can be sustained in such circumstances is severe, including the possible loss of eyesight. A shooter must always wear impact resistant shooting glasses when firing any firearm. Earplugs help reduce the chance of hearing damage from shooting.



• ALWAYS CHECK THE BARREL BORE, CHAMBER AND ACTION TO ENSURE THEY ARE PERFECTLY CLEAN AND CLEAR OF OBSTRUCTIONS.

Clean a fouled gun immediately for correct and safe function.

• DO NOT SMOKE WHILE HANDLING, LOADING OR SHOOTING ANY AMMUNITION, ESPECIALLY BLACK POWDER. Keep black powder in a closed container at all times, reclosing the container after each and every use.

• USE PROPER AMMUNITION.

Only use factory-loaded, new ammunition manufactured to industry specifications: CIP (Europe and elsewhere), SAAMI® (U.S.A.). Be certain that each round you use is in the proper caliber or gauge and type for the particular firearm. The caliber or gauge of the firearm is clearly marked on the barrels of shotguns and on the slide or barrel of pistols. The use of reloaded or remanufactured ammunition can increase the likelihood of excessive cartridge pressures, casehead ruptures or other defects in the ammunition which can cause damage to your firearm and injury to yourself or others nearby.



Always use an individual charge from a powder measure when loading a muzzleloading gun, never charging directly from a powder flask.

• NEVER SHOOT AT WATER OR AT A HARD SURFACE.

Shooting at the surface of water or at a rock or other hard surface increases the chance of ricochets or fragmentation of the bullet or shot, which can result in the projectile striking an unintended or peripheral target.

• Never shoot the gun near an animal, as the animal could be startled and create an accident.

• Never engage in "horseplay" while holding your gun.

• When selecting a place to shoot, always be absolutely sure of your target and the area behind it before you touch the trigger, making sure there is an adequate backstop which will stop and contain bullets. A bullet can travel through or past your target up to 1 1/2 miles. If you have any doubt, do not shoot.



• NEVER CLIMB A TREE, FENCE OR OBSTRUCTION WITH A LOADED FIREARM.

Open and empty the chamber of your firearm and engage the manual safety before climbing or descending a tree or before climbing a fence or jumping over a ditch or obstruction. Never pull or push a loaded firearm toward yourself or another person.

• Never follow a companion with your gun loaded.

• Place the hammer forward only when you are ready to shoot. Never place or permit the hammer to remain in the half-cock notch as this is not a safe carrying position. You might end up accidentally perching the hammer on the lip of the half cock notch, which is extremely dangerous. The hammer in this condition could fall forward and discharge the gun, causing injury, death, or property damage.



• Do not put your finger inside the trigger guard until you have aimed the gun at the intended target and are imminently ready to safely shoot.

• Always be aware of other people around you. Keep spectators or others to your rear. Keep hands and face clear and keep others clear of the ejection port as ejected spent cartridges can cause injury.

• Always use extreme care with a misfire or failure to fire. Keep the gun pointed in a safe direction and wait one full minute. This is because if hangfire or slow ignition has occurred, the round will still fire. If the round fails to fire after waiting, remove the magazine, eject the round and examine the primer. Immediately refer to a competent gunsmith if you notice the firing pin indent on the primer is light, off-center, or does not exist. Dispose of misfired rounds according to the ammunition manufacturer's instructions.

• Immediately cease shooting if your gun fails to properly function. Never force a jammed action, which can cause a round to explode and cause personal injury, death, or damage to your gun or other property.

• Never leave a gun, especially a loaded gun, unattended as someone, especially a child, could accidentally shoot it causing injury, death, or property damage.

• Make sure your gun is not loaded before cleaning, storing, traveling, laying it down, or handing

it to another person.

• STORE YOUR FIREARM SO THAT CHILDREN CANNOT GAIN ACCESS TO IT.

It is your responsibility to insure that children under the age of 18 or other unauthorized persons do not gain access to your firearm. To reduce the risk of accidents involving children, unload your firearm, lock it and store the ammunition in a separate locked location. Please note that devices intended to prevent accidents - for example, cable locks, chamber plugs, etc. - may not prevent use or misuse of your firearm by a determined person. Steel gun safes may be more appropriate to reduce the likelihood of intentional misuse of a firearm by an unauthorized child or person.

• Black powder and percussion caps must be stored in separate locations, preferably in their original containers.

• LEAD WARNING.

Discharging firearms in poorly ventilated areas, cleaning firearms or handling ammunition may result in exposure to lead and other substances known to cause birth defects, reproductive harm, and other serious physical injury. Have adequate ventilation at all times. Wash hands thoroughly after exposure.

• PROPERLY MAINTAIN YOUR FIREARM.

Store and carry your firearm so that dirt or lint does not accumulate in the working parts. Clean and oil your firearm, following the instructions provided in this manual, after each use to prevent corrosion, damage to the barrel or accumulation of impurities which can prevent use of the gun in an emergency. Always check the barrel prior to loading to ensure that it is clean and free from obstructions.

Firing against an obstruction can rupture the barrel and injure yourself or others nearby.

In case you hear an unusual noise when shooting, stop firing immediately, engage the manual safety and unload the firearm. Make sure the chamber and the barrel are free from any obstruction or possible bullet blocked inside the barrel due to defective or improper ammunition.



PRECAUTIONS

Read and understand all the following precautions before removing this firearm from the package.

The United States I.R.S., B.A.T.F. and treasury department classifies this product as a firearm or dangerous weapon; therefore, it is potentially lethal.

! WARNING: Careless and improper handling of this gun could result in unintended discharge causing injury, death or property damage. Safety must be the first and constant consideration when handling a firearm and ammunition.

CAUTION: Prior to removing this gun from its packaging, and prior to loading and shooting, carefully and thoroughly read this entire instruction manual which advises on the gun's proper functioning and handling. If you are unsure of anything, or have little experience or are unfamiliar with firearms, contact your local gun club, NRA approved instructor, or directly contact the National Rifle Association, Washington, D.C. 20036. Firearm safety is your responsibility and your safety and that of your family and others depend on your responsible, safe use.

NOTICE - DISCLAIMER OF LIABILITY

A. Uberti S.p.A. shall not be responsible for product malfunction or for physical injury, death, or property damage from the gun's intentional or accidental discharge, its criminal or negligent use, improper or careless handling, unauthorized modifications, corrosion or other failure to maintain, use of defective, improper, hand-loader or reloaded ammunition, or other than original, good condition, high quality, commercially manufactured ammunition, or from its use for purposes or subjection to treatments for which it was not designed. A. Uberti S.p.A. will not honor claims made by the second or subsequent owners of the firearm.

While this firearm was tested, carefully inspected, and packaged before it left the factory, A. Uberti S.p.A. cannot thereafter control product handling. Please be sure to examine this firearm carefully when purchased to ensure it is unloaded and undamaged. Your gun dealer will assist you in making this examination and answer any further questions in this regard.

! AMMUNITION

AMMUNITION WARNING: Since your gun has been designed for specific caliber ammunition, use only commercially manufactured ammunition which pressure cannot be higher than the ones stated by SAAMI or C.I.P. standards.

Factory ammunitions must be in excellent condition, of original high quality, and specifically recommended for the gun and nothing else.

Never use reloaded or hand-loaded ammunitions.

- The use of reloaded Ammunition voids the warranty.

Never carry the gun with a round in the chamber until ready to shoot.

Your gun has been designed for ammunition of a specific caliber - do not alter the barrel, chamber, caliber for which you gun was designed. Be sure you never mix ammunition.

- Use only ammunition specifically recommended for your firearm. (Proper Ammunition specified on barrel and cylinder).

SAFETY FEATURES

Safety devices, if used properly, can help minimize the danger of accidental firing.

NOTE: Read carefully your instruction manual on how to operate the safety devices on your gun. Safety devices on guns are extras and are not a substitute for your proper and safe handling practices.

WARRANTY NOTICE!!

CHARCOAL BLUE FINISH: Derives its name from the high-temperature fire blueing process involved in attaining the deep royal blue color. Charcoal Blue is **more delicate than standard blue:** the gun must be constantly oiled and with use will become a desirable smoke gray "patina" finish as on an antique gun.

NICKEL PLATED FINISH: This nickel plated finish is a superficial electrolytic process: these nickel plated firearms, after firing, the muzzle crown of the barrel and the cylinder may begin to show wear on close inspection. This is due to usage and is unavoidable.

WHITE FINISH: White finish is delicate. It is essential you look after your revolver. Acidity from you hand creates rust, therefore the gun must be oiled after handling or simply touching. Remember, your gun is not Stainless Steel.

WOOD: The manufacturer does not warrant the wood (stock, forend and grips) with respect to finish, matching of pieces, dents, scratches, cuts and dings etc.

METAL: The manufacturer does not warrant the metal finish, wood to metal fit etc.

The manufacturer assumes no responsibility for improper or careless handling, unauthorized modifications, use of defective, improper, hand-loaded, reloaded or remanufactured ammunition, customer abuse or neglect of the product.

This warranty does not apply to normal wear or any parts, or if an unauthorized repair and/or alteration has been performed.

All are firearms are subject to proof testing at the Italian National Proof House and are proofed at much higher pressures than normal pressures. Furthermore, the chamber dimensions and head space are tested according to the Saami and C.I.P. regulations.



A. Uberti S.p.A.

25063 Gardone V.T. (Brescia) Italy - Via Artigiani, 1
Phone +39.030.83 41 800 - Telefax +39.030.83 41 801
E-mail: info@ubertireplicas.it - www.ubertireplicas.com