



A. Uberti[®] S.p.A.
HISTORY REPEATS ITSELF



1875 S.A. SCHOFIELD

TOP BREAK SINGLE ACTION REVOLVER

INSTRUCTION MANUAL

1875 S.A. SCHOFIELD

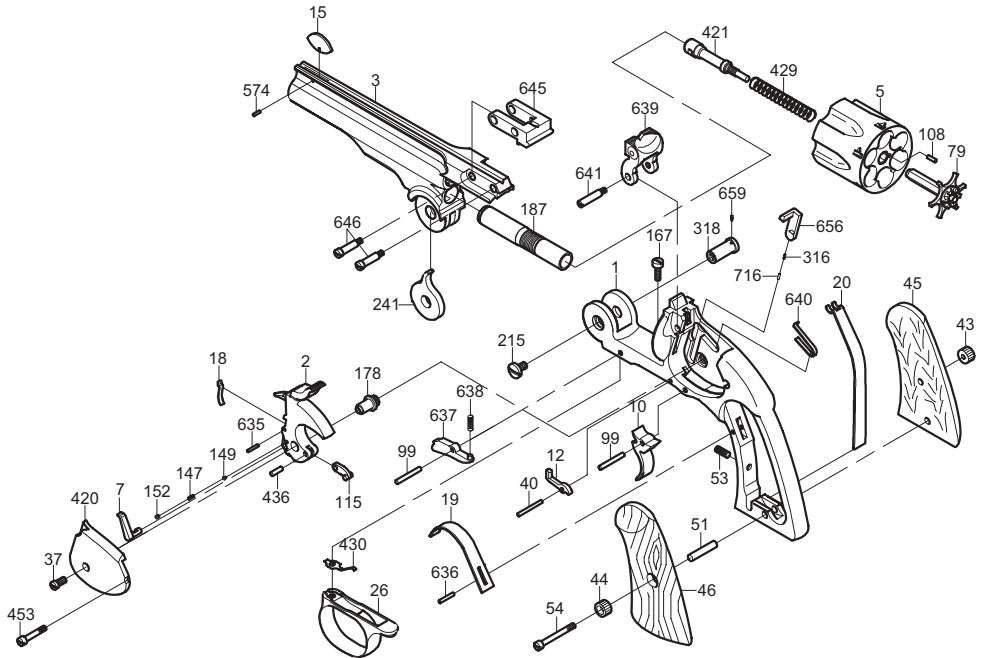

N.	Q.TY	DESCRIPTION
1	1	FRAME ASSEMBLY
2	1	HAMMER ASSEMBLY
3	1	BARREL ASSEMBLY
5	1	CYLINDER ASSEMBLY
7	1	HAND
10	1	TRIGGER
12	1	BOLT
15	1	SIGHT
18	1	HAND SPRING
19	1	TRIGGER SPRING
20	1	MAIN SPRING
26	1	TRIGGERGUARD
37	1	HAMMER SCREW
40	1	BOLT SCREW
43	1	RIGHT GRIP NUT
44	1	LEFT GRIP NUT
45	1	RIGHT GRIP
46	1	LEFT GRIP
51	1	GRIP PIN
53	1	MAINSRING SCREW
54	1	GRIP SCREW
79	1	EJECTOR .45
99	2	TRIGGER PIN
108	1	EXTRACTOR GUIDE PIN
115	1	STIRRUP
147	1	HAMMER SAFETY SPRING
149	1	HAMMER SAFETY PIN

N.	Q.TY	DESCRIPTION
152	1	HAMMER SAFETY STOP SCREW
167	1	TRIGGERGUARD SCREW
178	1	HAMMER PIN
187	1	BASE PIN BUSHING
215	1	HINGE PIN SCREW
241	1	EJECTOR CAM
316	1	SAFETY SPRING
318	1	HINGE PIN
420	1	SIDE PLATE
421	1	EJECTOR ROD
429	1	EJECTOR SPRING
430	1	BOLT SPRING
436	1	STIRRUP PIN
453	1	SIDE PLATE SCREW
574	1	SIGHT PIN
635	1	HAND SPRING PIN
637	1	EJECTOR LEVER
638	1	EJECTOR LEVER SPRING
639	1	STUD LATCH
640	1	STUD LATCH SPRING
641	1	STUD LATCH SCREW
645	1	BARREL BLOCK
646	2	BARREL BLOCK SCREW
656	1	SAFETY BLOCK
659	1	HINGE PIN PEG
716	1	SAFETY SPRING PIN

SPECIAL SAFETY INSTRUCTIONS



READ ALL INSTRUCTIONS AND WARNINGS. BEFORE USING YOUR UBERTI SINGLE ACTION FIREARM, CAREFULLY READ AND UNDERSTAND ALL OF THE WARNINGS, INSTRUCTIONS AND OTHER INFORMATION IN THIS MANUAL. DO NOT PERMIT OTHERS TO HANDLE THIS FIREARM UNLESS THEY HAVE ALSO READ AND UNDERSTAND THE INFORMATION IN THIS INSTRUCTION MANUAL. FAILURE TO DO SO COULD RESULT IN **SERIOUS INJURY OR DEATH.**



FIREARMS ARE NOT ALL ALIKE. Features and handling characteristics of this single action revolver may be different from other revolvers or firearms with which you are familiar; therefore, it is your responsibility to study this manual carefully and to thoroughly understand all of the operational and safety features of this revolver, how it functions and how to handle it safely. The best way to do this is to sit down with this manual and your unloaded revolver – without any ammunition nearby – and take as much time as is necessary for you to thoroughly understand how it works. **FIREARM SAFETY DEPENDS ON YOU!**



USE ONLY PROPER AMMUNITION. Discharging hand-loaded cartridges, ammunition marked “High Speed” or “High Velocity,” or cartridges of an incorrect caliber, can cause excessively high chamber pressures resulting in severe damage to your firearm and/or **SERIOUS INJURY OR DEATH.** Old cartridges can also deteriorate and damage your firearm. **NEVER use anything other than new cartridges that have been commercially loaded in accordance with SAAMI-C.I.P. standards.** ONLY use cartridges that are the exact caliber as the caliber of your revolver. Never mix ammunition.



Discharging any firearm carries risks of eye and ear injury WHICH CAN BE MINOR, MODERATE OR SERIOUS. Unprotected and repeated exposure to gunfire can cause hearing damage. Flying particles and debris can cause eye injury. Therefore, you should **ALWAYS** wear eye and ear protection when discharging a firearm.



A LOADED FIREARM is not a **TOY**. A loaded firearm is capable of causing **SERIOUS INJURY OR DEATH** if not treated with proper care. **DO NOT** engage in horseplay with a loaded firearm and do not leave a loaded firearm unattended.

This manual should always accompany this firearm and be transferred with it upon change of ownership.

THREE HAMMER POSITIONS:

There are three possible positions for the hammer of this single action revolver:

FIG.A. “Safety”, “Transport”, “Loading”, “Unloading” First cock position;

FIG.B. “Firing” Second cock position

FIG.C. “After Firing” At rest

Safety and Transport: First cock position (FIG.A)

These guns have a hammer block safety in the frame. To activate the hammer safety block, pull the hammer backward until you hear the first click. Lower the hammer into the safety position. With the hammer in this position, the safety mechanism is activated. This patented device places a steel insert between the hammer and the frame and is designed to prevent the gun from accidentally firing. When the gun is not being used, always use your hammer block safety. **(See FIG. A) (WARNING: NEVER LEAVE THE HAMMER FULLY FORWARD OVER A LIVE CARTRIDGE. IN THIS POSITION, A SHARP BLOW TO THE HAMMER – OR A DROPPED REVOLVER – CAN CAUSE AN ACCIDENTAL DISCHARGE AND SERIOUS INJURY OR DEATH COULD OCCUR.)**

Loading: First cock position (FIG.A)

Keeping your finger out of the trigger guard and off the trigger, draw the hammer back to the first cock position which makes the cylinder free to rotate. Then, open the revolver as far as it will open until the ejector returns to its normal position in the cylinder. Make certain you have the exact caliber cartridges matching the exact caliber of your revolver. Then load one cartridge in each chamber. Before closing your revolver, make sure the hammer is in first cock position. If the hammer is in full cock position (firing position), the gun will not close. Do not insist on closing because the hand is not in its correct position. Be careful because you could break the hand. You should practice this loading function without any cartridges until you feel comfortable. Then, and only then, are you and your revolver ready for use.

(WARNING: The user must manually move the hammer into this first cock position – **NOTICE:** This revolver does not have an “automatic” safety; therefore, the safety is not always on and must be engaged by user. **(Fig. A)**

Unloading: First cock position (FIG. A):

Point the gun in a safe direction. Draw the hammer back to the first cock position **(FIG. A)**. Turn the gun so the cylinder is facing downward, release the Stud Latch (P/N: 639) and completely open the gun. At this point all the cartridges will fall out contemporarily towards the ground **(FIG. D)**.

Firing Position (Full Cock) (FIG. B):

Pull the hammer backward in firing position (full cock). Make sure it clicks into this rearmost position. Your revolver is now ready to fire.

Never attempt to fire your gun in any position except the full cock position, Attempting to pull the trigger in the safety position will strain the mechanism and make it unsafe. (It might even break if you are strong enough). **Make certain you are using only new commercially loaded ammunition of the correct caliber. (WARNING: Do NOT use ammunition marked “High Speed” or “High Velocity” and NEVER use reloaded ammunition.)**

Position after Firing (FIG. C):

After firing, the hammer is resting against the frame and the firing pin would be resting on the primer of a chambered cartridge. **(WARNING: NEVER** leave the hammer fully forward over a live cartridge. In this position, a sharp blow to the hammer – or a dropped revolver – can cause an accidental discharge and **SERIOUS INJURY OR DEATH** could occur).

If your revolver is in the full cock position and you change your mind and do not want to fire, carefully follow the following instructions:

1. Point the gun in a safe direction.
2. Take your trigger finger out of the trigger guard and put this finger on the side of the frame. **(FIG. E)**
3. Release the stud latch (P/N: 639) and rotate the barrel fully open. **(FIG. E)**
4. Remove all cartridges and empty casings from your gun. **(FIG. D)**
5. Put your trigger finger on the trigger and your thumb on the hammer.
6. Pull the trigger backward and hold it while lowering the hammer. After the hammer has passed the full cock position (firing position) release the trigger and continue to lower the hammer until it clicks into the first cock position **(FIG. A)** Now you can

close the gun. **N.B. NEVER CLOSE THE GUN WHEN THE HAMMER IS IN THE FIRING POSITION.**

LOWERING THE HAMMER CAN BE DANGEROUS. Lowering the hammer on a single action firearm can be dangerous if you are not completely familiar with its handling characteristics. If the hammer slips during this process and a live cartridge is positioned under the hammer, an accidental discharge could occur causing **SERIOUS INJURY OR DEATH.** It is therefore critical that you first practice the above loading and unloading steps, including safely lowering the hammer, without any ammunition, or with dummy cartridges only, until you are comfortable and confident you can do so safely. **ALWAYS MAKE SURE THE MUZZLE IS POINTED IN A SAFE DIRECTION WHEN LOWERING THE HAMMER. REMEMBER, FIREARM SAFETY DEPENDS ON YOU!**

Before opening and closing your gun **MAKE SURE THE HAMMER IS IN THE SAFETY POSITION (FIG. A).** With the hammer in this position, the safety mechanism is activated.

Make sure your gun is always in the safety position when transporting or when you are not actually firing.

You must learn this procedure with an unloaded gun until you feel confident and are familiar with the handling.

Only when you feel really confident should you think about using live ammunition.

CLEANING AND MAINTENANCE

Before beginning any cleaning or maintenance procedures, **MAKE SURE** the revolver is unloaded. (**WARNING:** Failure to follow this step could lead to **SERIOUS INJURY OR DEATH.**)

Check first to make sure your revolver is empty. Pull the hammer rearward into first cock position (FIG:A), release the stud latch (P/N:639) and open the gun for cleaning. To clean your revolver, use a wood, aluminum or brass cleaning rod (do not use steel), a brass bristle brush, and patches that are correctly sized to the caliber of your revolver. Use a good quality cleaning solution to scrub each cylinder bore and barrel bore. Always brush all the way through the bore; never try to reverse directions while the brush is actually in the barrel or chamber. After scrubbing, run clean patches through the bore and chambers until they come out clean. Thereafter, completely, but lightly, oil the entire revolver. You will find that the oil will nicely color the one piece grip of your revolver over the years and it will develop and retain a soft patina glow. Use a good quality brass polish on the back strap and trigger guard. These high-quality solid brass parts will tarnish, but it is easily removed with any good quality brass polish.

CAUTION

Remember, when you full cock your gun to shoot it again, you rotate the cylinder; then you decide not to fire and decock the gun. This round is still live and will rotate back toward the firing position with each cocking. Do not forget about this round.

If you fired rounds prior to the decocking operation and commence firing again, the hammer will fall on one or more empty cylinders and still will fall on a live round. Be careful and attentive to this live round.

Always keep your gun pointed in a safe direction.

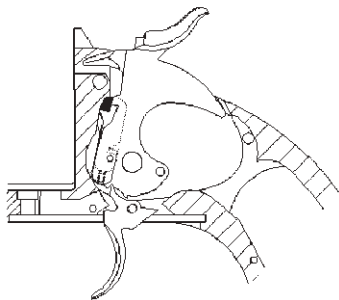

FIRST COCK
"SAFETY", "TRANSPORT", "LOADING", UNLOADING

A

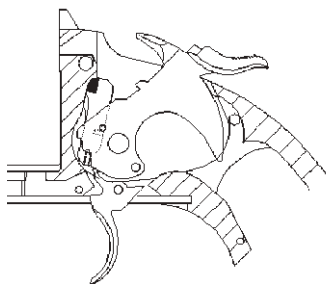

SECOND COCK
"FIRING"

B

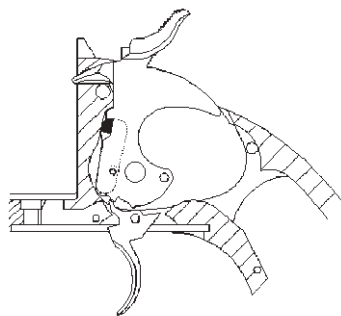

AT REST
"AFTER FIRING"

C



GENERAL SAFETY INSTRUCTIONS

Whether you are an experienced safe shooter and are familiar with these safety instruction procedures, or have some or no familiarity with handling a gun, it is imperative that you read carefully and thoroughly this entire instruction manual and follow the safety instructions to ensure you are familiar with the proper and safe use of this firearm to prevent personal injury, death, or property damage.

WARNING:

• NEVER POINT A FIREARM AT SOMETHING THAT IS NOT SAFE TO SHOOT.

Never let the muzzle of a firearm point at any part of your body or at another person. This is especially important when loading or unloading the firearm. When you are shooting at a target, know what is behind it. Some bullets can travel over a mile. If you miss your target or if the bullet penetrates the target, it is your responsibility to ensure that the shot does not cause unintended injury or damage.



• ALWAYS TREAT A FIREARM AS IF IT WERE LOADED.

Never assume that a firearm is unloaded. **The only certain way to ensure that a firearm has the chamber empty is to open the chamber and visually examine the inside to see if a round is present. Removing the magazine will not guarantee that a firearm is unloaded or cannot fire.** Shotguns and rifles can be checked by cycling or removing all rounds and by then opening and inspecting the chamber and the magazine tube for any remaining rounds.

• KNOW THE SAFETY FEATURES OF THE FIREARM YOU ARE USING, BUT REMEMBER: SAFETY DEVICES ARE NOT A SUBSTITUTE FOR SAFE HANDLING PROCEDURES.

Never rely solely on a safety device to prevent an accident. It is imperative that you know and use the safety features of the particular firearm you are handling, but accidents can best be prevented by following the safe handling procedures described in these safety rules and elsewhere in the product manual. To further familiarize yourself with the proper use of this or other firearms, take a Firearms Safety Course taught by an expert in firearms use and safety procedures.

• NEVER TRANSPORT A LOADED FIREARM.

Unload a firearm before putting it in a vehicle (chamber empty, magazine empty). Hunters and target shooters should load their firearm only at their destination. If you carry a firearm for self-protection, leaving the chamber unloaded can reduce the chance of accidental discharge.



- **AVOID ALCOHOLIC BEVERAGES OR JUDGMENT/ REFLEX IMPAIRING MEDICATION WHEN SHOOTING.**

Do not drink and shoot. If you take medication that can impair motor reactions or judgment, do not handle a firearm while you are under the influence of the medication.



- **ALWAYS WEAR PROTECTIVE GLASSES AND EARPLUGS WHEN SHOOTING.**

The chance that gas, gunpowder or metal fragments will blow back and injure a shooter who is firing a gun is rare, but the injury that can be sustained in such circumstances is severe, including the possible loss of eyesight. A shooter must always wear impact resistant shooting glasses when firing any firearm. Earplugs help reduce the chance of hearing damage from shooting.



- **ALWAYS CHECK THE BARREL BORE, CHAMBER AND ACTION TO ENSURE THEY ARE PERFECTLY CLEAN AND CLEAR OF OBSTRUCTIONS.**

Clean a fouled gun immediately for correct and safe function.

- **DO NOT SMOKE WHILE HANDLING, LOADING OR SHOOTING ANY AMMUNITION, ESPECIALLY BLACK POWDER.**

Keep black powder in a closed container at all times, reclosing the container after each and every use.

- **USE PROPER AMMUNITION.**

Only use factory-loaded, new ammunition manufactured to industry specifications: CIP (Europe and elsewhere), SAAMI® (U.S.A.). Be certain that each round you use is in the proper caliber or gauge and type for the particular firearm. The caliber or gauge of the firearm is clearly marked on the barrels of shotguns and on the slide or barrel of pistols. The use of reloaded or remanufactured ammunition can increase the likelihood of excessive cartridge pressures, casehead ruptures or other defects in the ammunition which can cause damage to your firearm and injury to yourself or others nearby.

Always use an individual charge from a powder measure when loading a muzzleloading gun, never charging directly from a powder flask.

• **NEVER SHOOT AT WATER OR AT A HARD SURFACE.**

Shooting at the surface of water or at a rock or other hard surface increases the chance of ricochets or fragmentation of the bullet or shot, which can result in the projectile striking an unintended or peripheral target.



- Never shoot the gun near an animal, as the animal could be startled and create an accident.
- Never engage in “horseplay” while holding your gun.
- When selecting a place to shoot, always be absolutely sure of your target and the area behind it before you touch the trigger, making sure there is an adequate backstop which will stop and contain bullets. A bullet can travel through or past your target up to 11/2 miles. If you have any doubt, do not shoot.

• **NEVER CLIMB A TREE, FENCE OR OBSTRUCTION WITH A LOADED FIREARM.**

Open and empty the chamber of your firearm and engage the manual safety before climbing or descending a tree or before climbing a fence or jumping over a ditch or obstruction. Never pull or push a loaded firearm toward yourself or another person.



- Never follow a companion with your gun loaded.
- Place the hammer forward only when you are ready to shoot. Never place or permit the hammer to remain in the half-cock notch as this is not a safe carrying position. You might end up accidentally perching the hammer on the lip of the half cock notch, which is extremely dangerous. The hammer in this condition could fall forward and discharge the gun, causing injury, death, or property damage.
- Do not put your finger inside the trigger guard until you have aimed the gun at the intended target and are imminently ready to safely shoot.
- Always be aware of other people around you. Keep spectators or others to your rear. Keep hands and face clear and keep others clear of the ejection port as ejected spent cartridges can cause injury.
- Always use extreme care with a misfire or failure to fire. Keep the gun pointed in a safe direction and wait one full minute. This is because if hangfire or slow ignition has occurred, the round will still fire. If the round fails to fire after waiting, remove the magazine, eject the round and examine the primer. Immediately refer to a competent gunsmith if you notice the firing pin indent on the primer is light, off-center, or does not exist. Dispose of misfired rounds according to the ammunition manufacturer’s instructions.
- Immediately cease shooting if your gun fails to properly function. Never force a jammed action, which can cause a round to explode and cause personal injury, death,

or damage to your gun or other property.

- Never leave a gun, especially a loaded gun, unattended as someone, especially a child, could accidentally shoot it causing injury, death, or property damage.
- Make sure your gun is not loaded before cleaning, storing, traveling, laying it down, or handing it to another person.

• STORE YOUR FIREARM SO THAT CHILDREN CANNOT GAIN ACCESS TO IT.

It is your responsibility to insure that children under the age of 18 or other unauthorized persons do not gain access to your firearm. To reduce the risk of accidents involving children, unload your firearm, lock it and store the ammunition in a separate locked location. Please note that devices intended to prevent accidents - for example, cable locks, chamber plugs, etc. - may not prevent use or misuse of your firearm by a determined person. Steel gun safes may be more appropriate to reduce the likelihood of intentional misuse of a firearm by an unauthorized child or person.



- Black powder and percussion caps must be stored in separate locations, preferably in their original containers.

• LEAD WARNING

Discharging firearms in poorly ventilated areas, cleaning firearms or handling ammunition may result in exposure to lead and other substances known to cause birth defects, reproductive harm, and other serious physical injury. Have adequate ventilation at all times. Wash hands thoroughly after exposure.

• PROPERLY MAINTAIN YOUR FIREARM.

Store and carry your firearm so that dirt or lint does not accumulate in the working parts. Clean and oil your firearm, following the instructions provided in this manual, after each use to prevent corrosion, damage to the barrel or accumulation of impurities which can prevent use of the gun in an emergency. Always check the barrel prior to loading to ensure that it is clean and free from obstructions. **Firing against an obstruction can rupture the barrel and injure yourself or others nearby.**



In case you hear an unusual noise when shooting, stop firing immediately, engage the manual safety and unload the firearm. Make sure the chamber and the barrel are free from any obstruction or possible bullet blocked inside the barrel due to defective or improper ammunition.

Read and understand all the following precautions before removing this firearm from the package.

The United States I.R.S., B.A.T.F. and treasury department classifies this product as a firearm or dangerous weapon; therefore, it is potentially lethal.

CAUTION: Prior to removing this gun from its packaging, and prior to loading and shooting, carefully and thoroughly read this entire instruction manual which advises on the gun's proper functioning and handling. If you are unsure of anything, or have little experience or are unfamiliar with firearms, contact your local gun club, NRA approved instructor, or directly contact the National Rifle Association, Washington, D.C. 20036. Firearm safety is your responsibility and your safety and that of your family and others depend on your responsible, safe use.

NOTICE - DISCLAIMER OF LIABILITY

A. Uberti S.p.A. shall not be responsible for product malfunction or for physical injury, death, or property damage from the gun's intentional or accidental discharge.

A. Uberti S.p.A. assumes no responsibility for improper or careless handling, unauthorized modifications, use of defective, improper, hand-loaded, reloaded or remanufactured ammunition, customer abuse or neglect of the product.

A. Uberti S.p.A. will not honor claims made by the second or subsequent owners of the firearm.

While this firearm was tested, carefully inspected, and packaged before it left the factory, A. Uberti S.p.A. cannot thereafter control product handling. Please be sure to examine this firearm carefully when purchased to ensure it is unloaded and undamaged. Your gun dealer will assist you in making this examination and answer any further questions in this regard.

WARRANTY NOTICE!!

CHARCOAL BLUE FINISH: Derives its name from the high-temperature fire blueing process involved in attaining the deep royal blue color. Charcoal Blue is **more delicate than standard blue:** the gun must be constantly oiled and with use will become a desirable smoke gray “patina” finish as on an antique gun.

NICKEL PLATED FINISH: This nickel plated finish is a superficial electrolytic process: these nickel plated firearms, after firing, the muzzle crown of the barrel and the cylinder may begin to show wear on close inspection.
This is due to usage and is unavoidable.

WHITE FINISH: White finish is delicate. It is essential you look after your revolver. Acidity from you hand creates rust, therefore the gun must be oiled after handling or simply touching. Remember, your gun is not Stainless Steel.

WOOD: The manufacturer does not warrant the wood (stock, forend and grips) with respect to finish, matching of pieces, dents, scratches, cuts and dings etc.

METAL: The manufacturer does not warrant the metal finish, wood to metal fit etc.

This warranty does not apply to normal wear of any parts, or if an unauthorized repair and/or alteration has been performed.

All are firearms are subject to proof testing at the Italian National Proof House and are proofed at much higher pressures than normal pressures. Furthermore, the chamber dimensions and head space are tested according to the Saami and C.I.P. regulations.



NEW MODEL
FRONTIER (N°3)



1875 RUSSIAN



A. Uberti[®] S.p.A.
HISTORY REPEATS ITSELF

A. Uberti S.p.A.
Via Artigiani, 1 - 25063 Gardone Val Trompia (Brescia) Italy
Phone +39 030 8341 800 - Fax +39 030 8341 801
E-mail: info@ubertireplicas.it - www.ubertireplicas.com